

DETAIL A  
SCALE 1 : 10

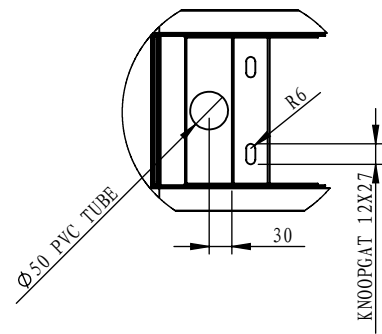
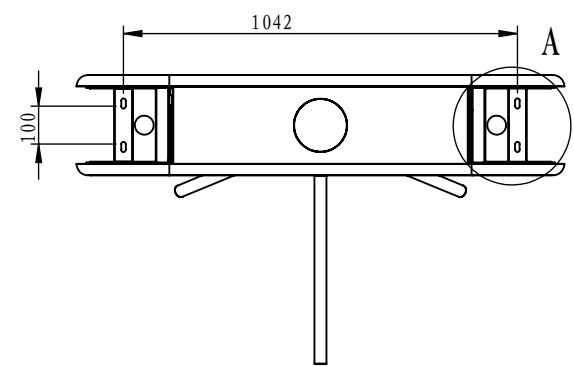

- INSTALLATION:**
1. FIXING THE EQUIPMENT WITH M10X80 EXPANSION BOLT
  2. ARRANGING WIRES WITH Ø50PVC TUBE; THE POWER WIRE FOR THE EQUIPMENT IS 3G2.5 SQUARE

**EXPANSION BOLT IS INSTALLED IN ELLIPSE TO FIX THE EQUIPMENT, AND CONTROL LINE AND POWER LINE ARE IMPORTED FROM Ø50PVC**

				TITLE: TRIPOD TURNSTILES			DWG. NO. : ES3000	
REVISION MARK	NUMBER OF REVISION	SIGNATURE	DATE	MATERIALS:			PROJECTIVE MARK	FINISH
DESIGNED							—  —	
DRAWN				VERSION	NUMBERS	SCALE	TOTAL: PAGE	SHENZHEN ESSENCE INFORMATION TECHNOLOGY CO., LTD
CHECKED							PAGE:	
STANDARDIZATION								
APPROVED								